

LOW VOLTAGE TRACKS

ST2

DOUBLE EMISSION LOW VOLTAGE 4 CONDUCTORS TRACK 9500-1/B-ST2 9500-1/W2-ST2

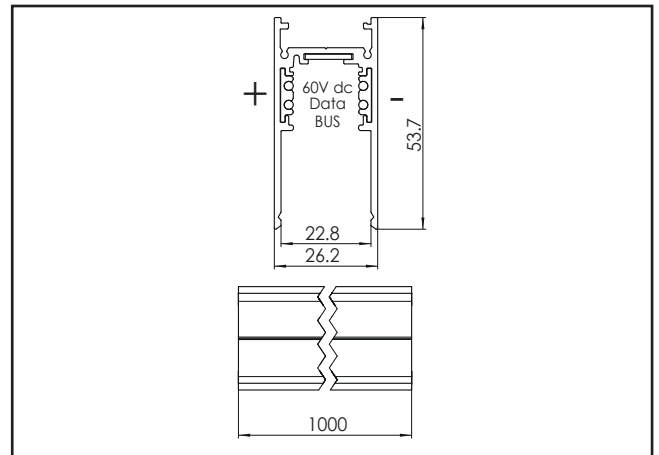

Technical data

• Rated current and voltage

15A / 60V dc

Characteristics

- 2 circuits: 2x +/- 15A/0-60V dc
- 1 circuit + Data Bus: +/- 15A/0-60V + D+/D-
- Length: 1000 mm, 2000mm, 3000 mm
- External extruded body in aluminium.
- Available colours: Embossed black RAL 9005(B) and embossed white RAL 9016 (W2)
- Insulated extruded body in PVC
- Copper conductors
- Quality marks : Class 2 (2A - 48Vdc / 4A - 24V dc )
- European directives : "RoHS" compliant
- Net weight 1039.9g
- Track for both polarized and non polarized versions



Suspension
mounting



Class III

LOW VOLTAGE TRACKS

ST2

Track accessories



S-9500/MIC-3000
MICROPRISMATIC SCREEN TL=87%

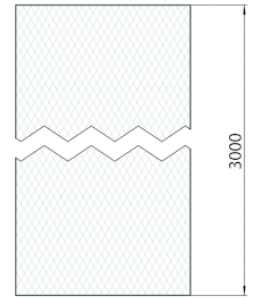
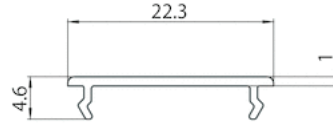

S-9500/OPN-3000
OPAL SCREEN TL=56%

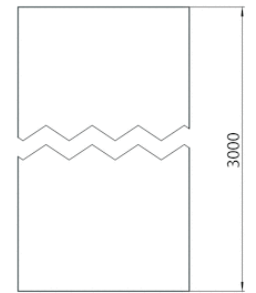
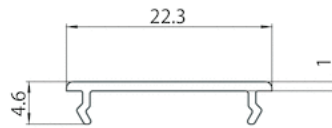

S-9500/TR-3000
TRANSPARENT SCREEN TL=90%

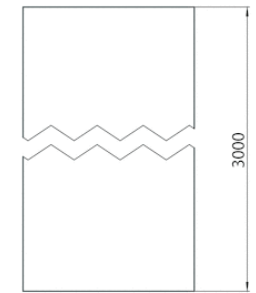
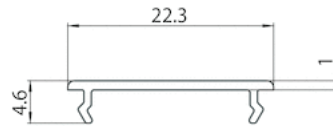

S-9500-L/B
PLASTER INSTALLATION GUARD

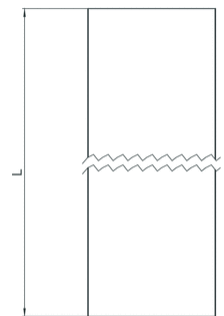
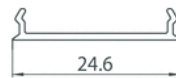

S-9500/LE-B-3000 S-9500/LE-W2-3000
OPAL SCREEN TL=56%

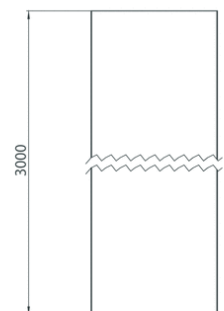

LOW VOLTAGE TRACKS

ST2

Track accessories

9504/ST2-B-F 9504/ST2-W2-F 9504/ST2-B 9504/ST2-W2

END CAPS



9504/ST2-B-F
9504/ST2-W2-F



9504/ST2-B
9504/ST2-W2

9504/ST2-... 9504/ST2-...-F

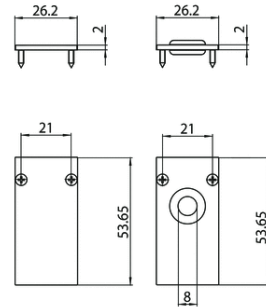

9504/ST2-P-B-F 9504/ST2-P-W2-F 9504/ST2-P-B 9504/ST2-P-W2

END CAPS

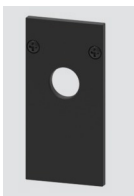

9504/ST2-P-B-F
9504/ST2-P-W2-F



9504/ST2-P-B
9504/ST2-P-W2

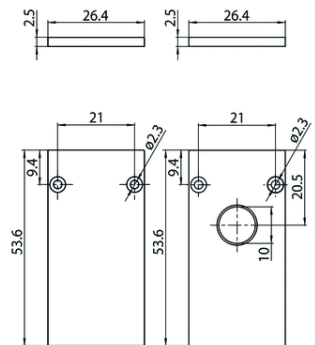

S-9000/T

CUTTING TOOL FOR TRACK CONDUCTORS

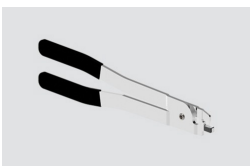

Connections



9501-S/B-E
9501-S/W-E
SHORT END-FEED



Snap - in
Fixing



Terminals with
screw and nut

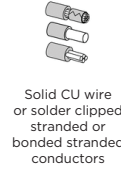

Solid CU wire
or solder clipped
stranded or
bonded stranded
conductors



Wires
stripping



SELV
Class III

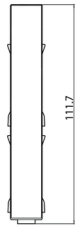

9503-S/B-E
9503-S/W-E
JOINTING CONNECTOR



Snap - in
Fixing



SELV
Class III

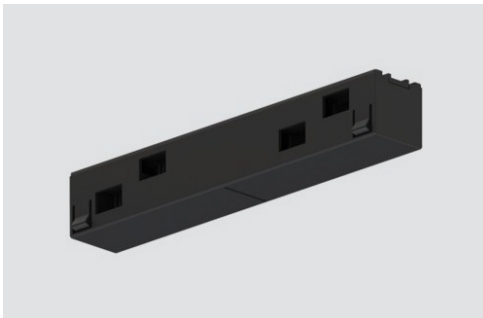
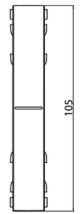

9503-S/B-M-E
9503-S/W-M-E
MECHANICAL JOINTING CONNECTOR



Snap - in
Fixing



SELV
Class III

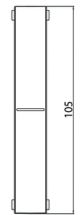

9511/B-E
9511/W-E
L FEED



Snap - in
Fixing



SELV
Class III

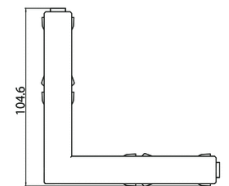

9518-S/B-E
9518-S/W-E
ADJUSTABLE CORNER



Snap - in
Fixing



SELV
Class III

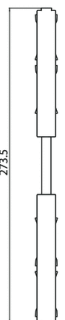

LOW VOLTAGE TRACKS

ST2

Connection joinings accessories



S-9511/B-ST2
S-9511/W2-ST2
COVER FOR L JOINT
FOR ST2 TRACK

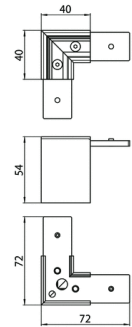

S-9511/316-LA
L BRACKET FOR ANGLES

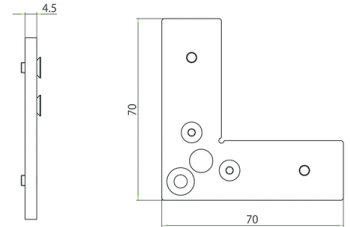

Complete suspension kits



9500-KIT1-1,5
9500-KIT1-3
9500-KIT1-5
COMPLETE SUSPENSION KIT

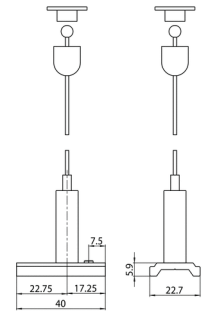

9500-KIT2-1,5
9500-KIT2-3
9500-KIT2-5
COMPLETE SUSPENSION KIT

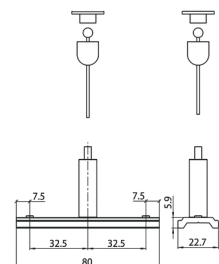

Suspension sets



S-9000-P3-B
S-9000-P3-W2
SUSPENSION SET

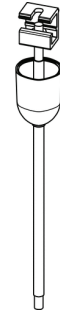

S-9000-P5-B
S-9000-P5-W2
SET FOR CEILING MOUNTING
WITH CUP AND TERMINAL BLOCK

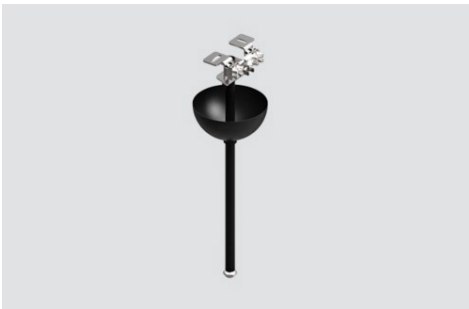
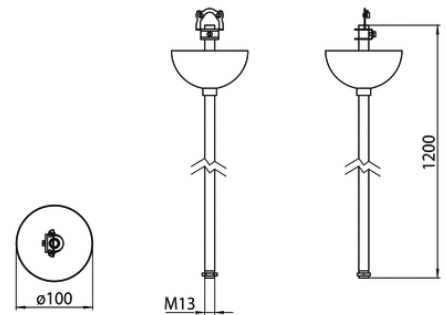

S-9000-P6-P-B
S-9000-P6-P-W2
SUSPENSION SET

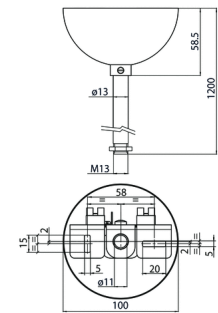

S-9000-P6-S-B
S-9000-P6-S-W2
SUSPENSION SET

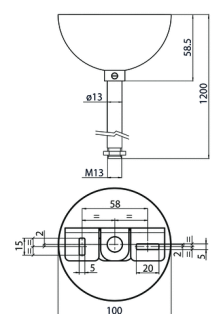

S-RE-P-B
S-RE-P-W2
SET FOR CEILING MOUNTING
WITH CUP AND TERMINAL BLOCK

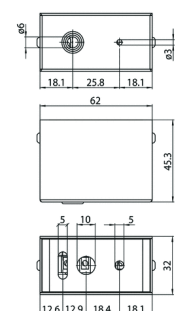

Brackets



S-9500/313-LA
SHORT BRACKET FOR SUSPENSIONS

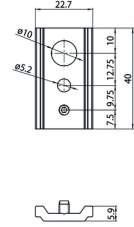

S-9500/323-LA
BRACKET FOR "IN ROW" USE JUNCTION

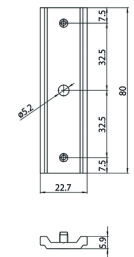

S-9500/313-M6
SHORT BRACKET FOR SUSPENSIONS

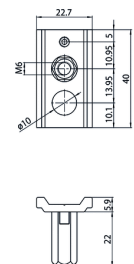

S-9500/323-M6
BRACKET FOR "IN ROW" USE JUNCTION

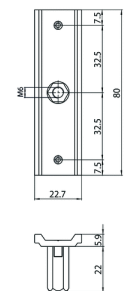

Brackets

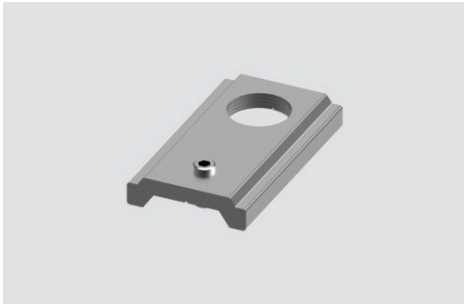

S-9500/313-M13
SHORT BRACKET FOR SUSPENSIONS

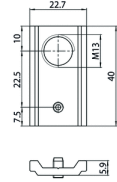

S-9500/323-M13
BRACKET FOR "IN ROW" USE JUNCTION

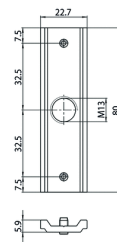

S-9500/313-SV
SHORT BRACKET FOR SUSPENSIONS

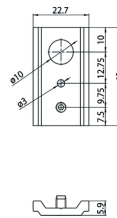

S-9500/323-SV
BRACKET FOR "IN ROW" USE JUNCTION

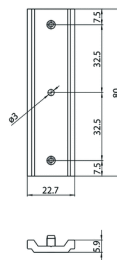

Clamp



S-9500/114-B
S-9500/114-W2
CEILING CLAMP

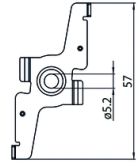

S-9500/114-T-B
S-9500/114-T-W2
TRACK FAST FIXING CLAMP
WITH GRIPPER

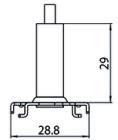
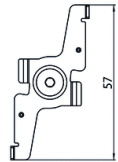

S-9500/115
S-9500/115-B
S-9500/115-W2
TRACK FAST FIXING CLAMP

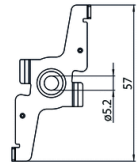

LOW VOLTAGE TRACKS

ST2

Cups



S-9000/3-B
S-9000/3-W
PLASTIC CUP FOR STEEL CABLE Ø 1,5 MM

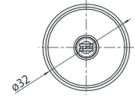
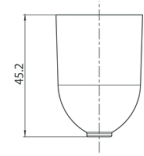

S-9000/216
ROUND HEAD CEILING ATTACHMENT WITH HOLE

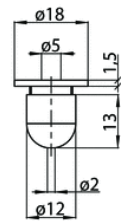

Ceiling fixing Brackets



S-9000/132
CEILING BRACKET FOR SUSPENSIONS

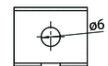
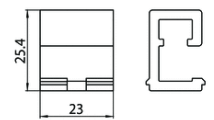
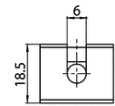

Stem



S-9000-1,2/604-B
S-9000-1,2/604-W2
STEM WITH M13x1 END AND NUT



LOW VOLTAGE TRACKS

ST2

Cables



S-9000/211-1,5
S-9000/211-3
S-9000/211-5

STEEL CABLE

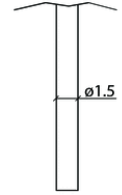

S-9000/211-S-1,5
S-9000/211-S-3
S-9000/211-S-5

STEEL CABLE WITH SPHERICAL END

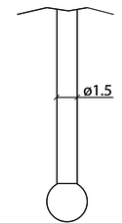

Grippers



S-9000/214
AUTOMATIC LOCK

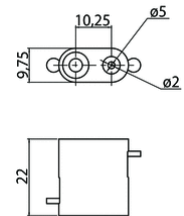

S-9000/215
SCREW GRIPPER

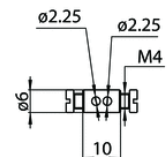

Grippers



S-9000/218
AUTOMATIC M5 GRIPPER WITH SIDE HOLE

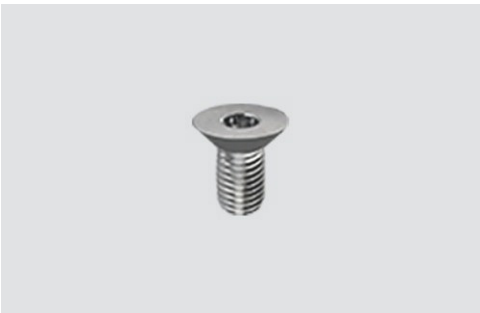
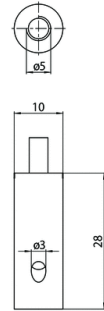

602/F
SET SCREW FOR GRIPPER ON THE BRACKET

