

# VINCO ADTR S.S.LED

INSTALLATION INSTRUCTIONS FOR LUMINAIRE VINCO ADTR S.S.LED

## INSTALL THE ADAPTER

Fit adapter on track. **Notice:** Select 0 circuit  
Turn the mechanical fixing knob (1).

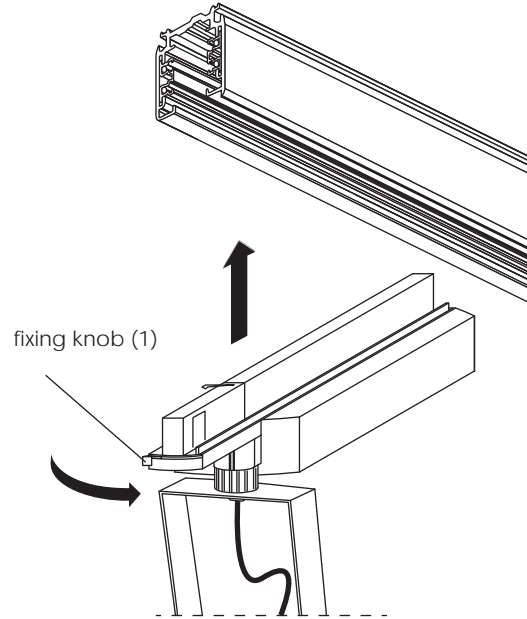
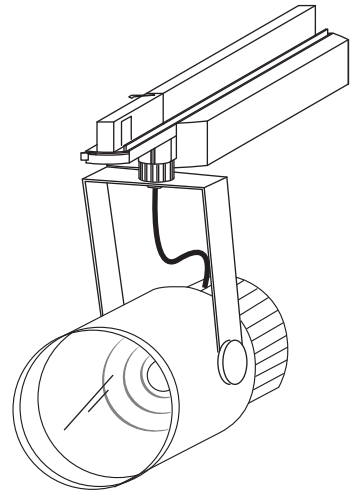

Turn the mechanical fixing knob (2).

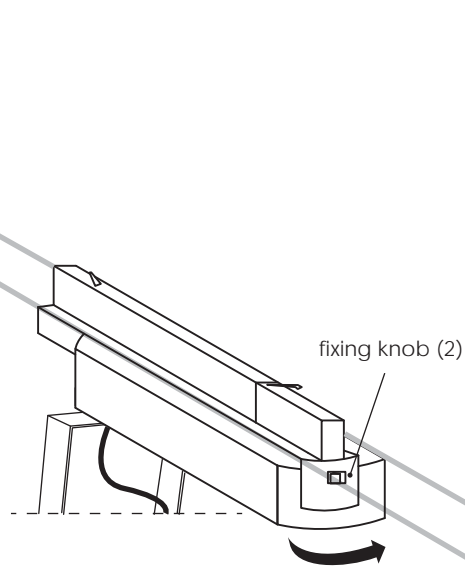

Select the desired circuit.

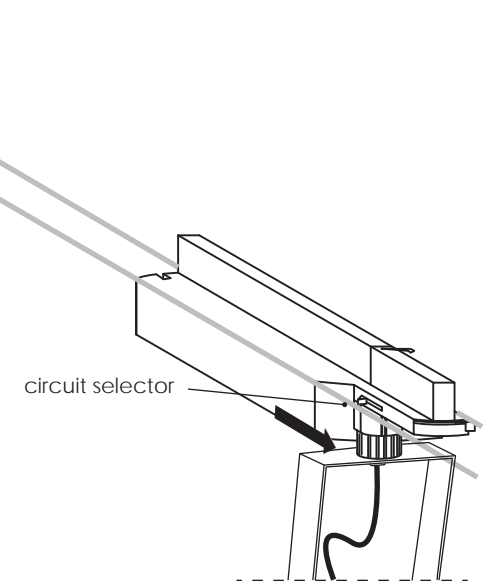

## USER INSTRUCTIONS

- The installation of the unit must be done by a qualified electrician.
- The unit must be earthed in case an earth connecting point exists.
- Ensure that the mains is switched off during servicing.
- Do not use bulb(s) bigger than the indicated on units name-plate or packaging.
- Ensure that after the installation, the unit is properly fixed and the cable clamps (if exist) are well tightened.
- Manufacturer will not accept liability for injury or damage resulting from incorrect use or installation
- The unit is not intended to operate in loop connection.
- Wall plugs and terminals are not included.
- LED modules are replaced only by the manufacturer.

## CAUTION

Wear anti-static gloves  
before you touch LED systems

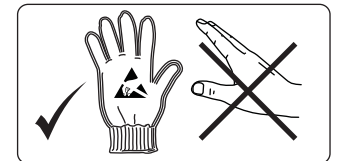

Date Issued: July 2016

**BRIGHT**  
SPECIAL LIGHTING

[www.bright.gr](http://www.bright.gr)

Factory: 5 Kefalovrisou Str., Monomati, Acharnai, P.O. Box 13677, Athens, Greece  
Tel: (+30) 210 6208 230 Fax: (+30) 210 62 08 262 E-mail: [info@bright.gr](mailto:info@bright.gr)

