

# PENDO 1R Q ADTR S.S.LED

INSTALLATION INSTRUCTIONS FOR LUMINAIRE PENDO 1R Q ADTR S.S.LED

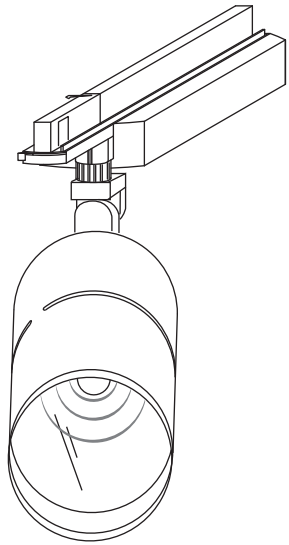

Weight: 1.50 kgr

## Safety

Verify the maximum weight carrying capacity of the track, before installing the spotlight.

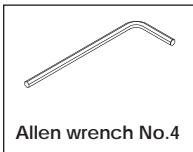

## INSTALL THE ADAPTER

Fit adapter on track. **Notice:** Select 0 circuit

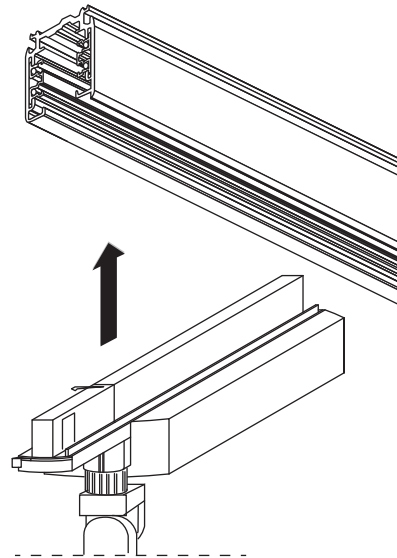

Turn the mechanical fixing knob (2).

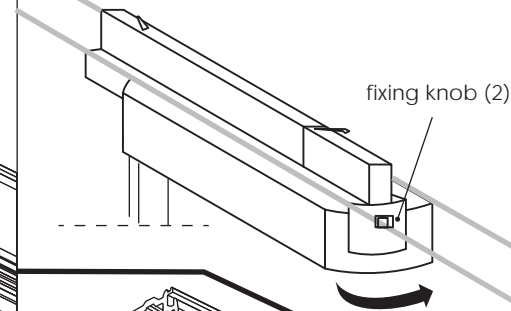

Turn the mechanical fixing knob (1).

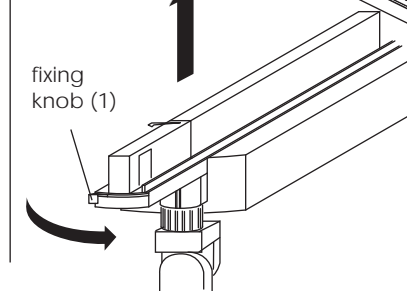

Select the desired circuit.

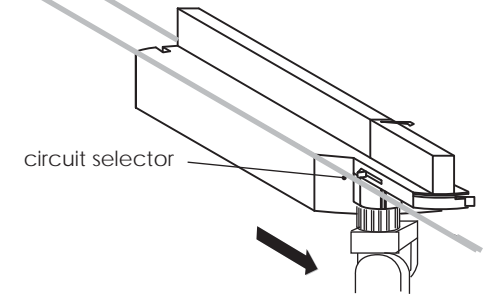

**CAUTION** The fixture should be **OFF** (0 circuit)  
Loosen the allen screw to rotate the luminaire.  
Then tighten it .

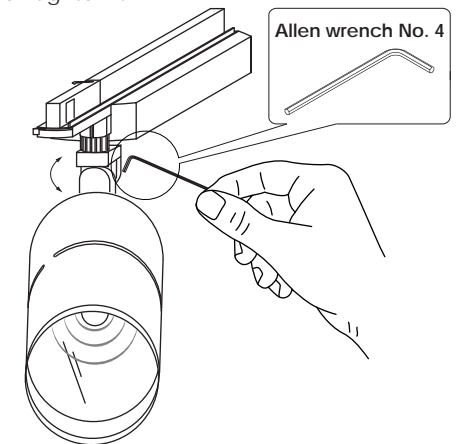

## USER INSTRUCTIONS

- The installation of the unit must be done by a qualified electrician.
- The unit must be earthed in case an earth connecting point exists.
- Ensure that the mains is switched off during servicing.
- Do not use bulb(s) bigger than the indicated on units name-plate or packaging.
- Ensure that after the installation, the unit is properly fixed and the cable clamps (if exist) are well tightened.
- Manufacturer will not accept liability for injury or damage resulting from incorrect use or installation
- The unit is not intended to operate in loop connection.
- Wall plugs and terminals are not included.
- LED modules are replaced only by the manufacturer.

## CAUTION

Wear anti-static gloves before you touch LED systems



## CAUTION

Replace any cracked shield



Date Issued: October 2016

**BRIGHT**  
SPECIAL LIGHTING

www.bright.gr

Factory: 5 Kefalovrisou Str., Monomati, Acharnai, P.O. Box 13677, Athens, Greece  
Tel: (+30) 210 6208 230 Fax: (+30) 210 62 08 262 E-mail: info@bright.gr

