

FORTIS Q LED

INSTALLATION INSTRUCTIONS FOR LUMINAIRE FORTIS Q LED

1 Installation

Unscrew the base with an allen wrench

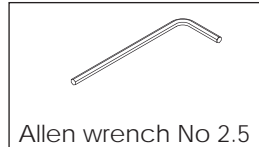
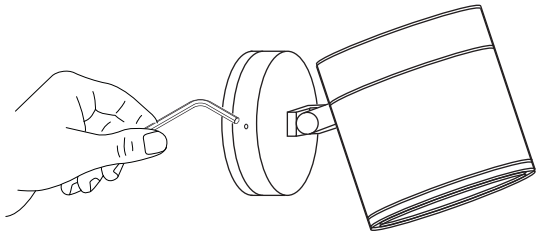

Allen wrench No 2.5

2 Screw base on the wall.
Please notice the silicone gasket.
Do not remove it

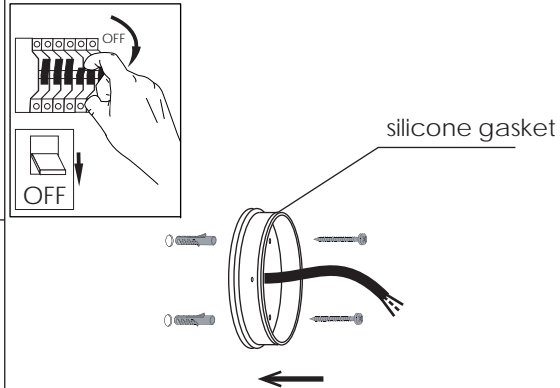

3 Make wiring connections

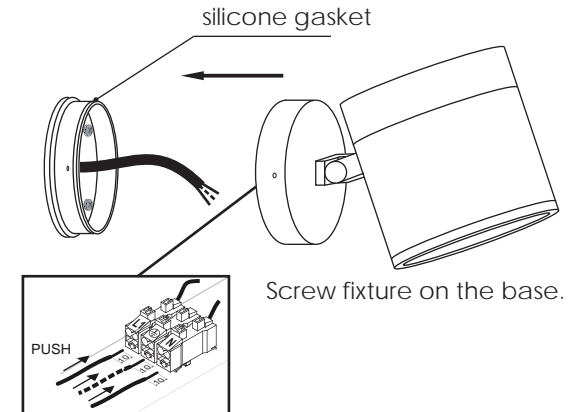

4 Rotate to focus

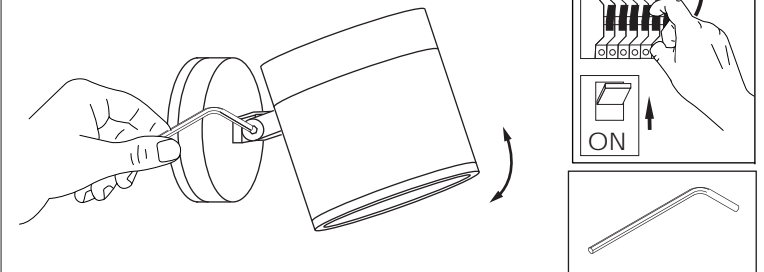

Allen wrench
No 4

USER INSTRUCTIONS

- The installation of the unit must be done by a qualified electrician.
- The unit must be earthed in case an earth connecting point exists.
- Ensure that the mains is switched off during servicing.
- Do not use bulb(s) bigger than the indicated on units name-plate or packaging.
- Ensure that after the installation, the unit is properly fixed and the cable clamps (if exist) are well tightened.
- Manufacturer will not accept liability for injury or damage resulting from incorrect use or installation
- The unit is not intended to operate in loop connection.
- Wall plugs and terminals are not included.
- LED modules are replaced only by the manufacturer.

CAUTION

Wear anti-static gloves
before you touch LED systems

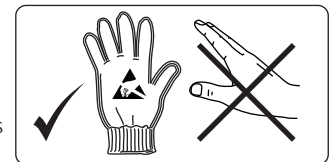

Last update: MAR 2018