

# PALIO 1 L LED



## ■ PRODUCT BENEFITS

- Uniform light and wide beam angle
- Energy savings of up to 50 %  
(compared to luminaires that use fluorescent lamps)
- Easy installation, no tools required for connection
- 5 years guarantee
- High luminous efficacy
- Lifetime >60.000h L85B10

## ■ AREAS OF APPLICATION

- Industrial and storage facilities
- Car parks and underpasses
- Garages
- Workshops, assembly lines

## ■ EQUIPMENT / ACCESSORIES

- INOX clamps with safety screws included
- Mounting accessories included  
(suspension kit, installation kit)
- INOX clips for securing the diffuser



CONVERSION  
KIT+BATTERY



INOX  
CLIPS



INOX  
MOUNTING  
BRACKET

# TECHNICAL DATA

## Electrical Data

Nominal Voltage	220-240V
Mains Frequency	50/60Hz
Power Factor $\lambda$	>0,95
Operating Mode	Integral ECG for LED modules
Output Current Ripple	≤1%

## Photometric Data

Standard Deviation of Color Matching (SDCM)	3 SDCM
CRI	>80
Beam Angle	120°
Transmittance	88% (FROSTED)   75% (OPAL)
Efficiency	Up to 175 lm/W

## Output Data

### Length ( 1200mm )

Wattage (W)	CCT (K)	Diffuser	Lumen Output	Efficiency
17W	3.000K	FROSTED	2.600 Lm	150 Lm/W
		OPAL	2.200 Lm	130 Lm/W
	4.000K	FROSTED	2.700 Lm	159 Lm/W
		OPAL	2.300 Lm	135 Lm/W
21W	3.000K	FROSTED	3.000 Lm	142 Lm/W
		OPAL	2.600 Lm	124 Lm/W
	4.000K	FROSTED	3.200 Lm	152 Lm/W
		OPAL	2.800 Lm	133 Lm/W
25W	3.000K	FROSTED	3.500 Lm	140 Lm/W
		OPAL	3.000 Lm	120 Lm/W
	4.000K	FROSTED	3.700 Lm	148 Lm/W
		OPAL	3.200 Lm	128 Lm/W
29W	3.000K	FROSTED	4.000 Lm	138 Lm/W
		OPAL	3.400 Lm	117 Lm/W
	4.000K	FROSTED	4.200 Lm	145 Lm/W
		OPAL	3.600 Lm	124 Lm/W

### Length ( 1500mm )

Wattage (W)	CCT (K)	Diffuser	Lumen Output	Efficiency
21W	3.000K	FROSTED	3.200 Lm	152 Lm/W
		OPAL	2.700 Lm	128 Lm/W
	4.000K	FROSTED	3.400 Lm	162 Lm/W
		OPAL	2.900 Lm	138 Lm/W
26W	3.000K	FROSTED	3.800 Lm	146 Lm/W
		OPAL	3.200 Lm	123 Lm/W
	4.000K	FROSTED	4.000 Lm	154 Lm/W
		OPAL	3.400 Lm	131 Lm/W
31W	3.000K	FROSTED	4.400 Lm	142 Lm/W
		OPAL	3.800 Lm	123 Lm/W
	4.000K	FROSTED	4.600 Lm	148 Lm/W
		OPAL	4.000 Lm	129 Lm/W
36W	3.000K	FROSTED	5.000 Lm	138 Lm/W
		OPAL	4.200 Lm	117 Lm/W
	4.000K	FROSTED	5.200 Lm	145 Lm/W
		OPAL	4.500 Lm	125 Lm/W

# TECHNICAL DATA

## ■ Dimensions

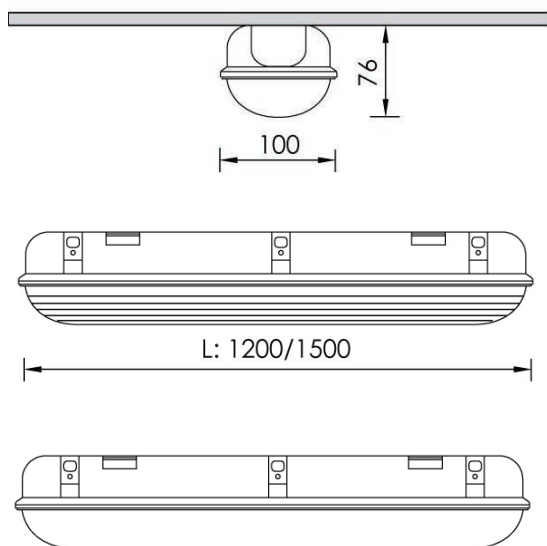

## ■ Weight

L:1200 1,55kg

L:1500 1,85kg

## ■ Colors & Materials

Body Material ABS

Diffuser Material FROSTED UV-Resistant Polycarbonate , OPAL UV-Resistant Polycarbonate

## ■ Temperatures & Operating Conditions

Ambient Temperature Range -30 ... +45°C

Ambient Relative Humidity Range 10 ... 95% R.H

Storage Temperature -30 ... +75°C

Max. Ambient Temperature for Lifetime +25°C

Lifetime at 25°C > 60.000h L85B10

# TECHNICAL DATA

## Safety Characteristics

Impact Resistant (IK)	IK 08
Ingress Protection (IP)	IP 65
Protection Class	Class I
Glow Wire Test	650°C
Photobiological Safety	RG0
Certifications	CE   ENEC

## General Characteristics

Dimmable	Upon request
Emergency Lighting	Upon request
Connection Type	Screwless terminal
LED module Replaceable	Only by the manufacturer
Mounting Type	Suspended / Surface
Mounting Location	Ceiling / Wall

## Light Distribution

### Frosted cover

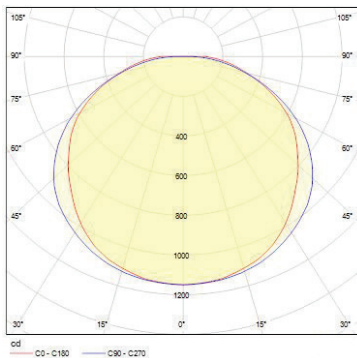

### Opal cover

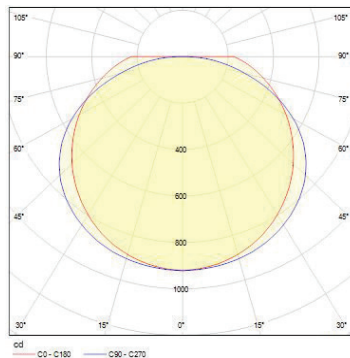

# REFERENCES | LINKS

---

## ■ Applications

---

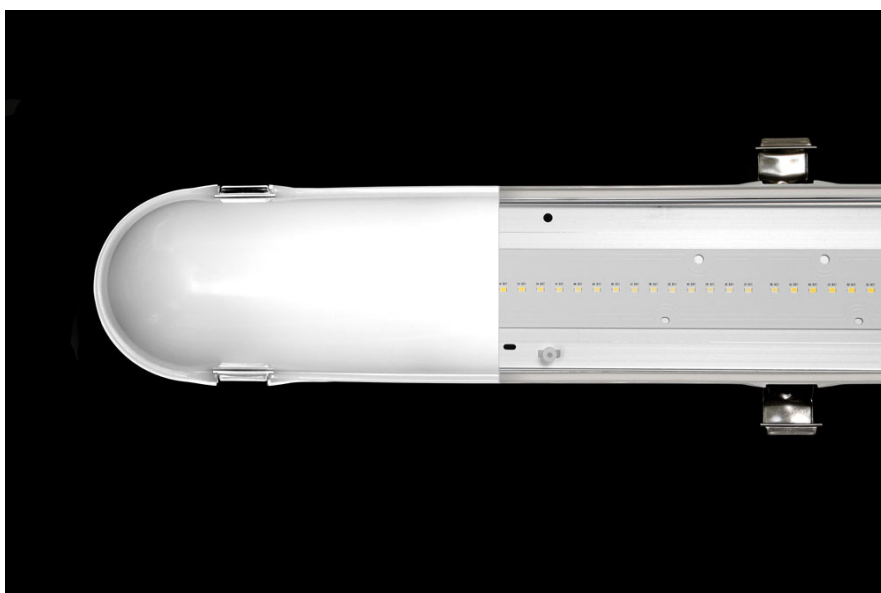
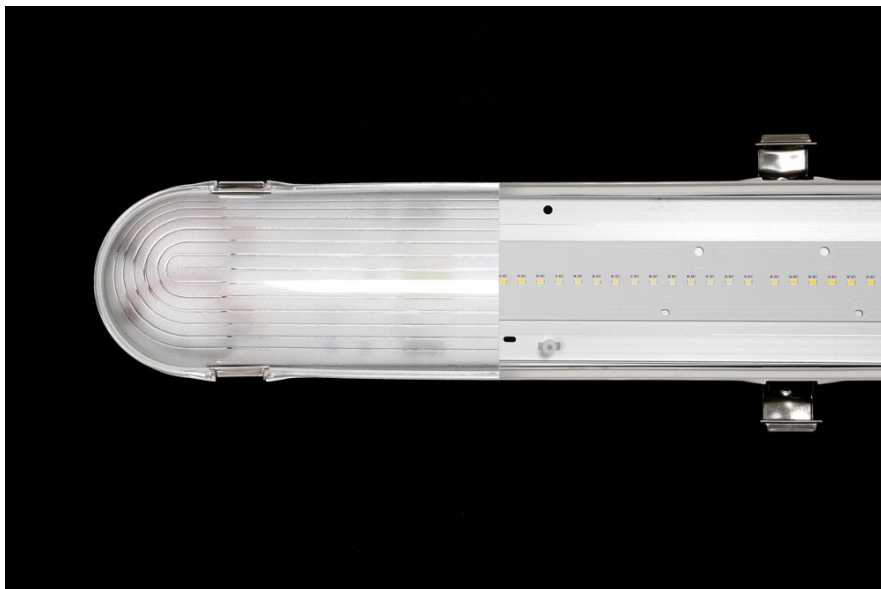

### ■ For warranty details see :

[https://www.bright.gr/uploads/files/2020/06/warranty\\_periods\\_v1\\_8\\_4804.pdf](https://www.bright.gr/uploads/files/2020/06/warranty_periods_v1_8_4804.pdf)

### ■ Warranty terms and conditions :

[https://www.bright.gr/uploads/files/2018/07/3013\\_3244.pdf](https://www.bright.gr/uploads/files/2018/07/3013_3244.pdf)