

# MACTO 1 S.S.LED

⊕ outdoor/ bollards

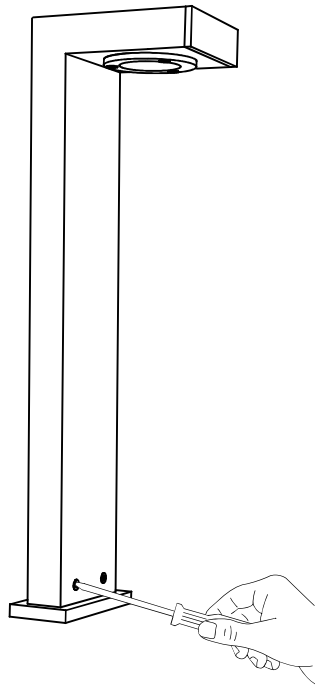

**1** Unscrew the base of the bollard.



**2** Screw the base on the ground. Pass the cable through the cable gland and tighten the nuts. Make a **watertight electric connection**.

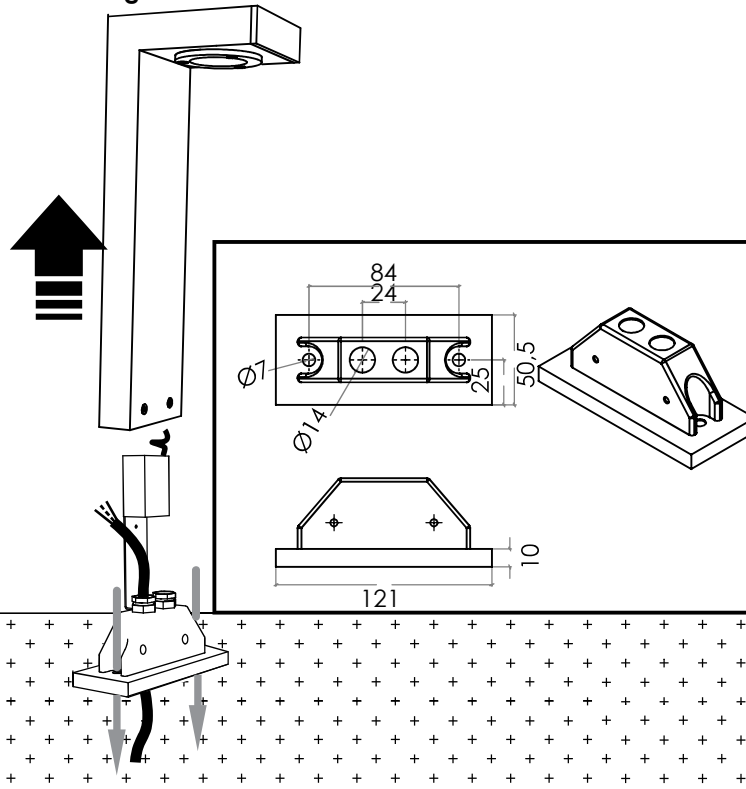
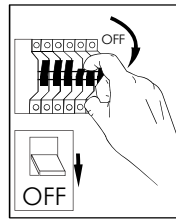

**3** Attach the bollard on the base and tighten the (4) screws.

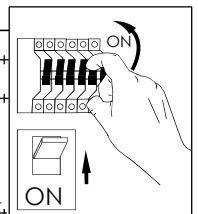
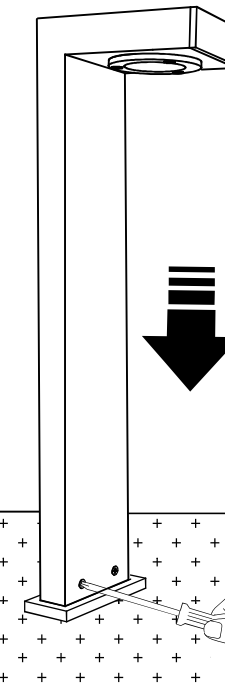

**USER INSTRUCTIONS**

- The installation of the unit must be done by a qualified electrician.
- The unit must be earthed in case an earth connecting point exists.
- Ensure that the mains is switched off during servicing.
- Do not use bulb(s) bigger than the indicated on units name-plate or packaging.
- Ensure that after the installation, the unit is properly fixed and the cable clamps (if exist) are well tightened.
- Manufacturer will not accept liability for injury or damage resulting from incorrect use or installation
- The unit is not intended to operate in loop connection.
- Wall plugs and terminals are not included.
- LED modules are replaced only by the manufacturer.



**CAUTION**  
Replace any cracked shield